



Bike Fit Machine Instructions Manual



Exustar Enterprise Co. Ltd.

Copyright 2018 © Exustar Enterprise Co. Ltd.

Exustar is a trademark of Exustar Enterprise Co. Ltd. All rights reserved. All other trademarks are the property of their respective owners. **Specifications subject to change without notice.** Made in Taiwan.

www.exustar.com

Artwork: 03-2018, Doc: ELO170

No.111, Aly. 23, Ln. 430, Wang-Fu St., Dadu Dist.,
Taichung City 432, Taiwan (R.O.C.)

Tel: +886 4 26937999 Fax: +886 4 26938777

Email: exustar@ms76.hinet.net



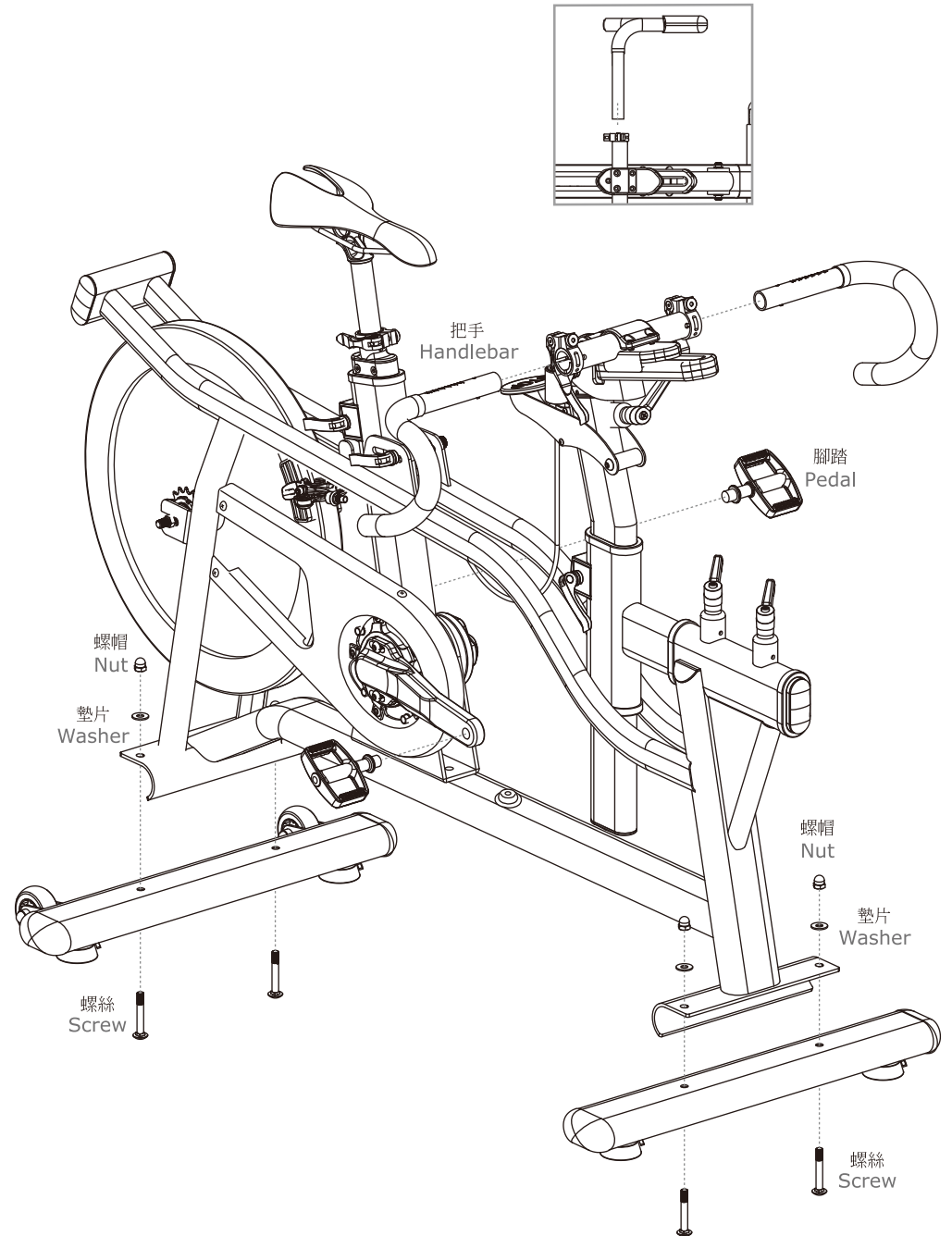
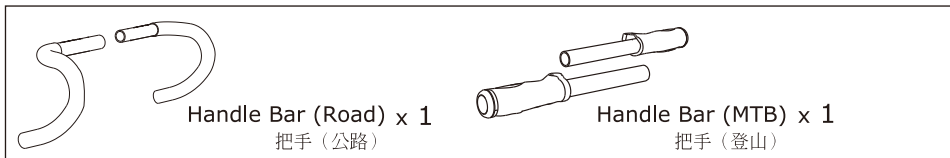
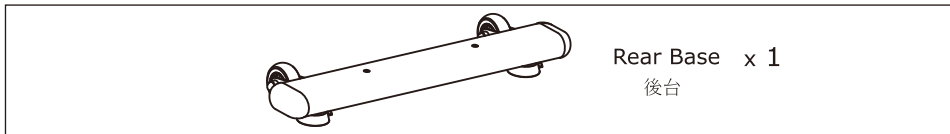
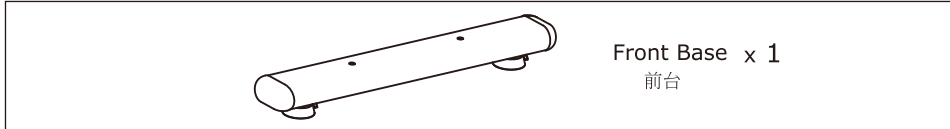

INSTRUCTIONS

Preparation:

A. Choose a bicycle frame that is approximately the right size for you.

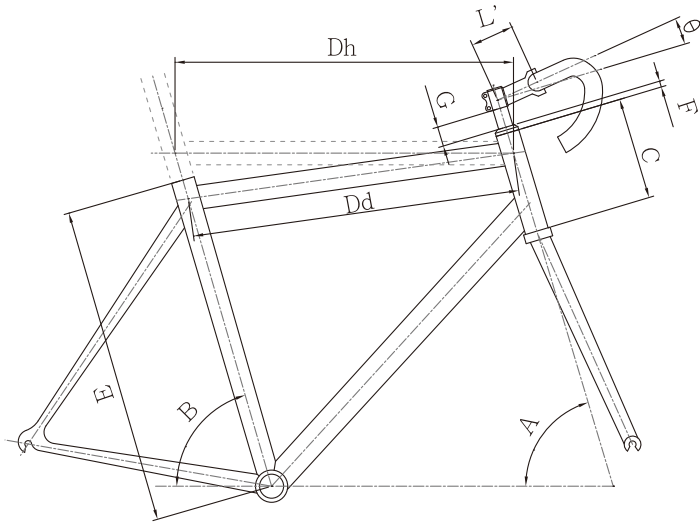

B. Adjust the height for both front and rear base and use level instrument to make sure the bubble is in the center position.

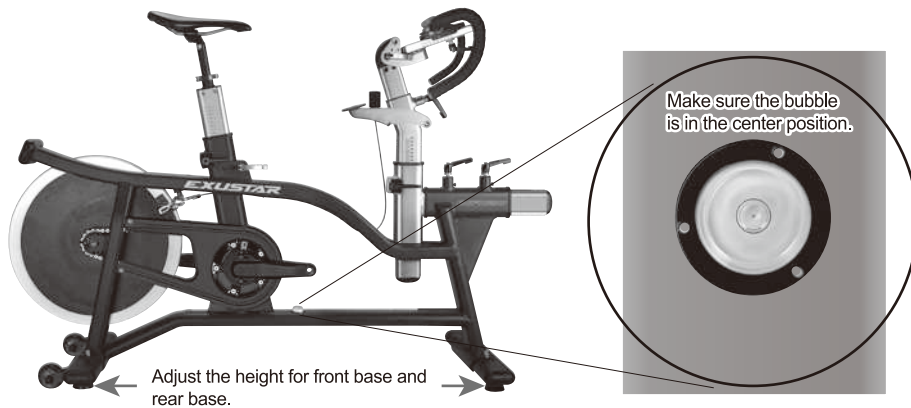

1. Head Tube Height Adjustment (Stack): Range 500-650mm

See fig. A. Loosen QR lever on 'fork.' Raise or lower head tube to desired height (refer to measurement markings). Retighten QR lever.

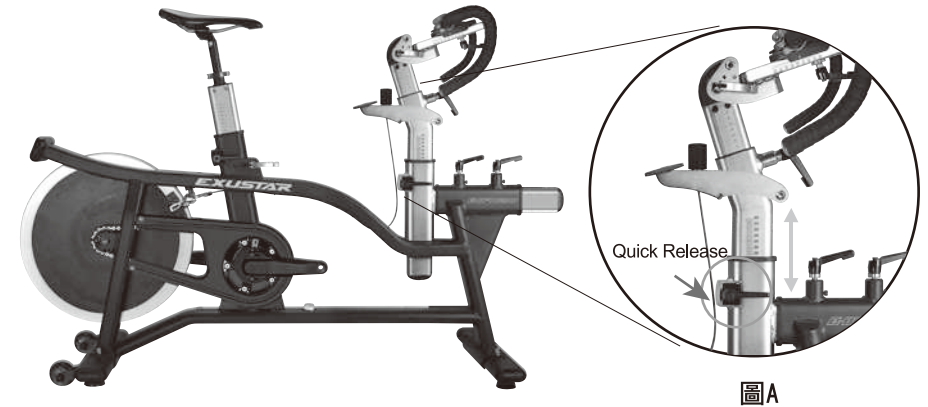

2. Top Tube Length Adjustment (Reach): Range 350-420mm

Loosen QR levers for top tube (See fig. B), move forward or back to desired length (refer to measurement markings). Retighten QR levers.

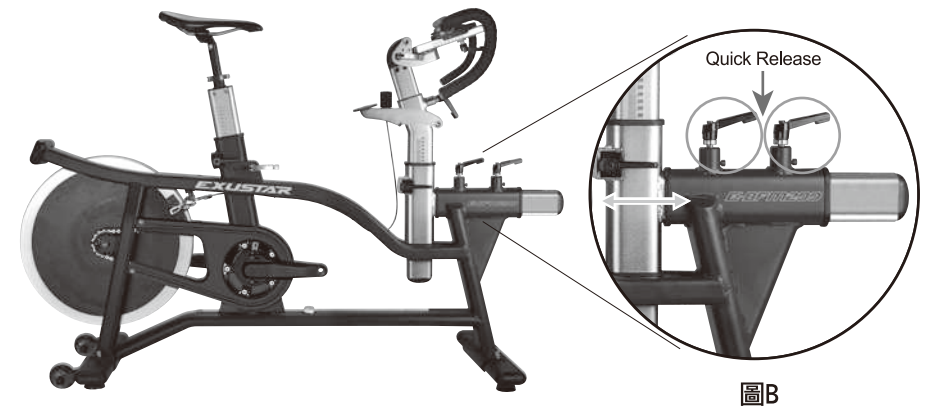

3. Seat Tube Angle Adjustment

Step 1: Put angle gauge on the frame, set the dial to 0°.

Step 2: Loosen angle adjustment QR levers of Seat Tube and put the angle gauge on the seat tube, then adjust the angle of seat tube to desired angle (See fig. C). Retighten QR lever.

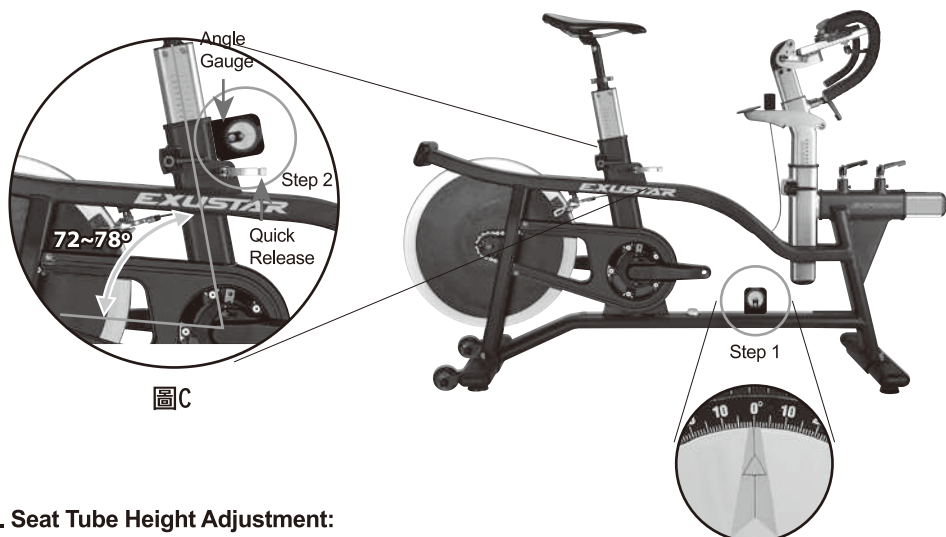

4. Seat Tube Height Adjustment:

Loosen height adjustment QR levers of Seat Tube, pull up and down to adjust the height of Seat Tube to desired height (See fig. D). Retighten QR lever.

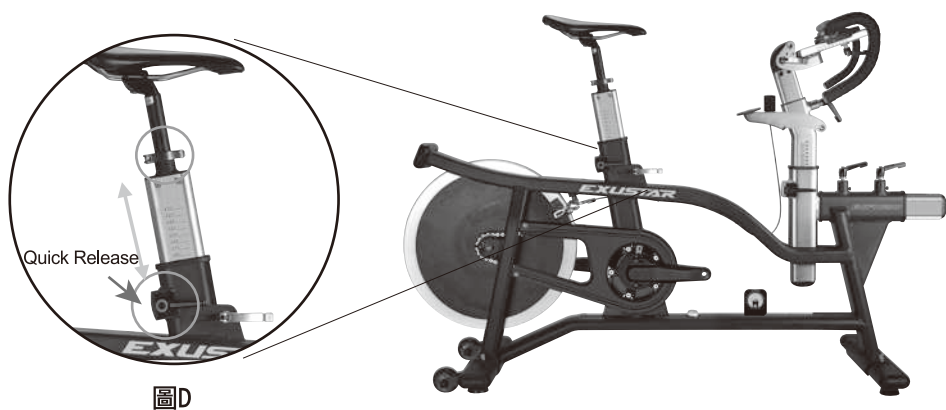

5. Stem Height Adjustment:

Loosen height adjustment QR lever of stem, pull up and down to desired height. Retighten QR lever. (See fig. E)

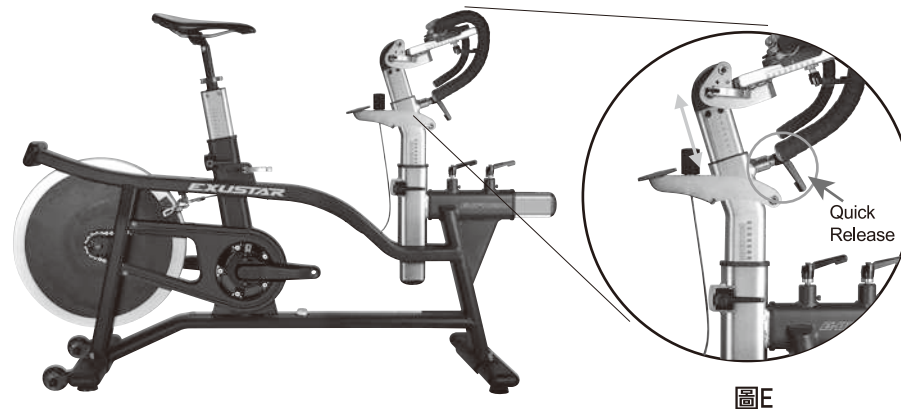

6. Stem Angle Adjustment: Range $\pm 12^\circ$

Step 1: Put angle gauge on the front of Stem, set the dial to 90°.

Step 2: Loosen angle adjustment QR lever of Stem, put the angle gauge on the Stem, the pointer of angle gauge if at left side, means minus degree, if at right side, means plus degree, adjust the Stem to desired angle. Retighten QR lever. (See fig. F)

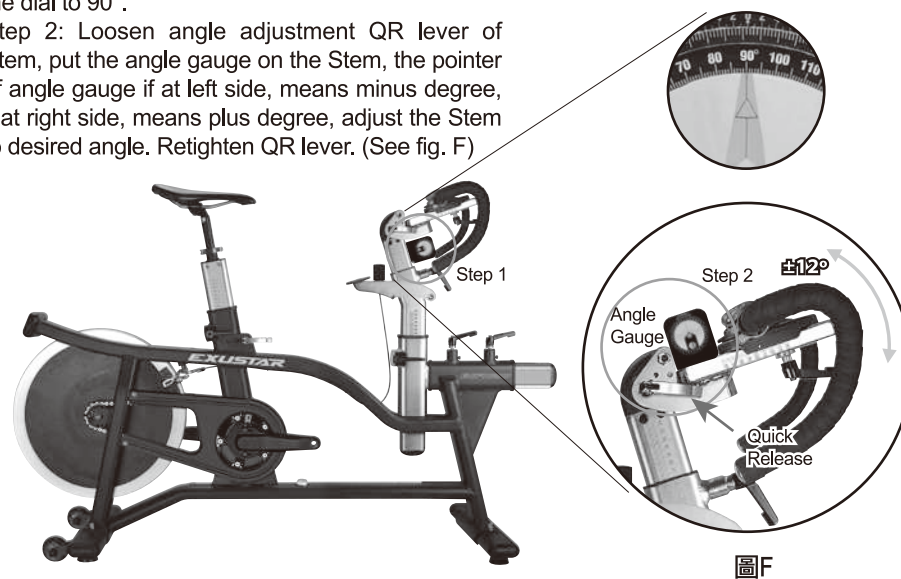

7. Stem Length Adjustment:

Loosen length adjustment QR levers of Stem, adjust the stem to desired position. Retighten QR lever. (See fig. G)

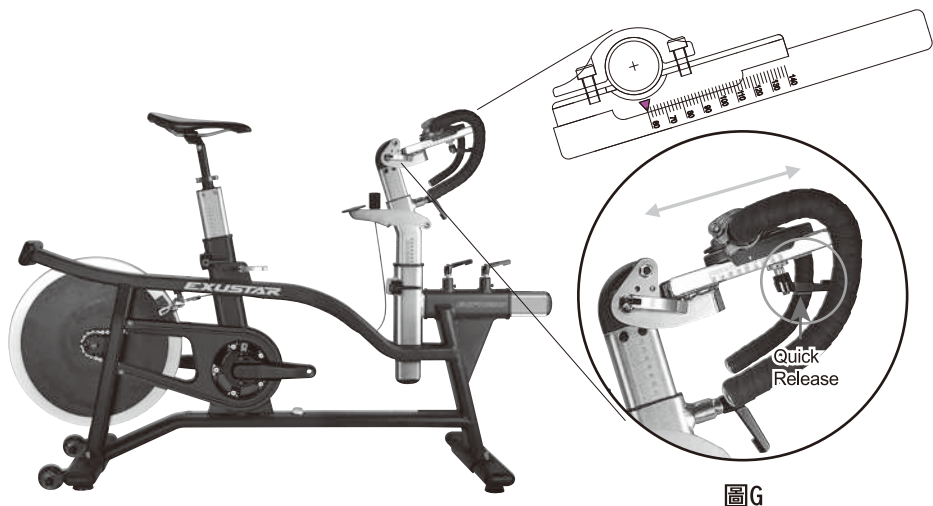

9. Flywheel Brake:

Push the Stop button to stop the flywheel. (See fig. I)

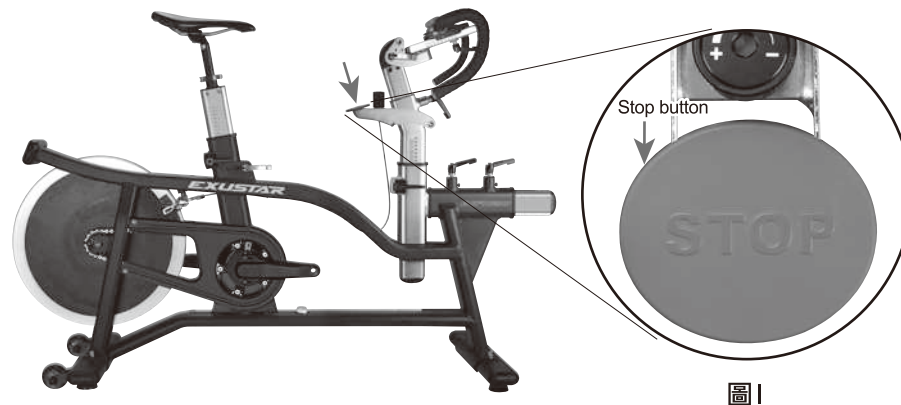

8. Flywheel Resistance Rotary:

Use rotary in a clockwise direction to reduce the resistance, or in a counterclockwise direction to increase the resistance. (See fig. H)

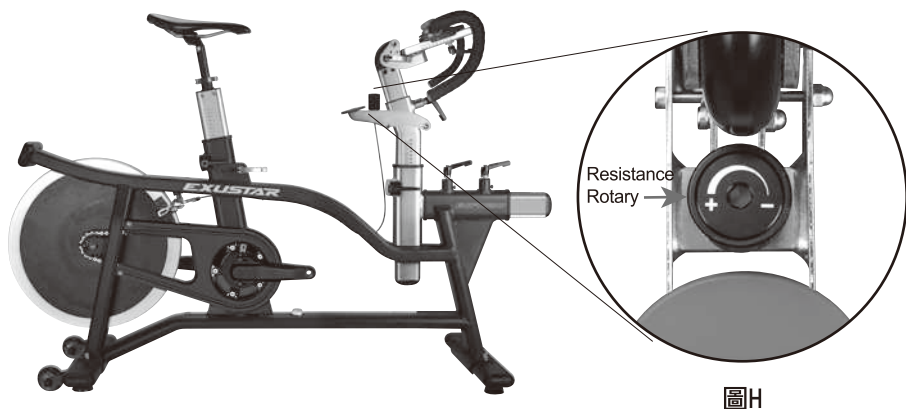

10. Handlebar Width Adjustment:

Loosen both QR levers on handlebar. Adjust width of both sides equally to desired length (refer to measurement markings). Retighten QR levers.

Allen bolts Measurement markings

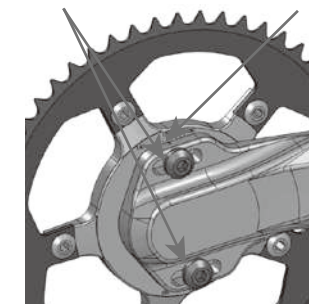

11. Crank Length Adjustment:

With a 6 mm Allen key, loosen bolts on crank arm on chain wheel side. Adjust crank arm to desired length (refer to measurement markings). Retighten Allen bolts. Repeat process on second crank arm, (both crank arms are normally set to same length).

圖H

12. Changing the Handlebar Type:

Your bike fit measurement machine comes with two sets of handlebars: road drop bars, and straight bars. To change bar type, undo 2 quick releases, and replace bars. Retighten quick releases.

Note: flat handlebar measurement does not include any extra width added by hand grips. Drop handlebar measurement means the distance from left bar end to right bar end.

Fit Bike 是一個可以模擬理想車架進而微調至最適合騎乘者的相關零件尺寸的量測工具。店家應先量測騎乘者的體型，挑選出最適合此騎乘者的車架，利用此量身車模擬出所選車架，進而可以讓騎乘者利用此量身車測試此車架是否為其最合適的選擇或是需要那些部分的微調而進行調整。

調整開始前準備工作：

A. 選擇一台適合騎乘者的車架幾何尺寸

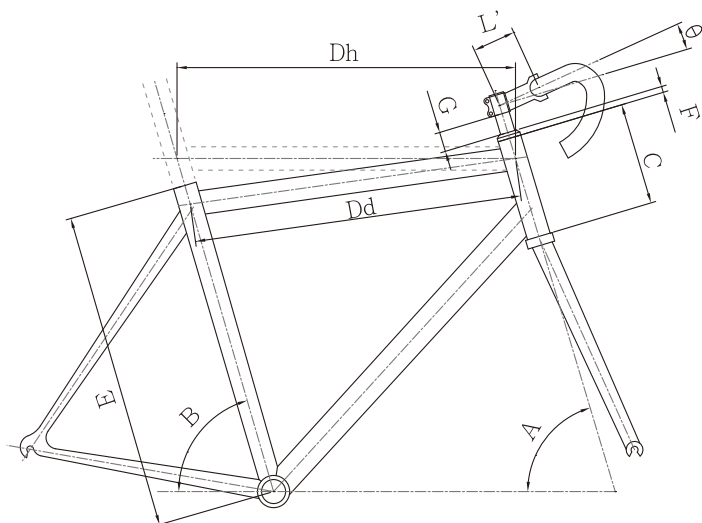

B. 調整前後貼地管支撐架高度，直至水平儀之氣泡於中心位置。

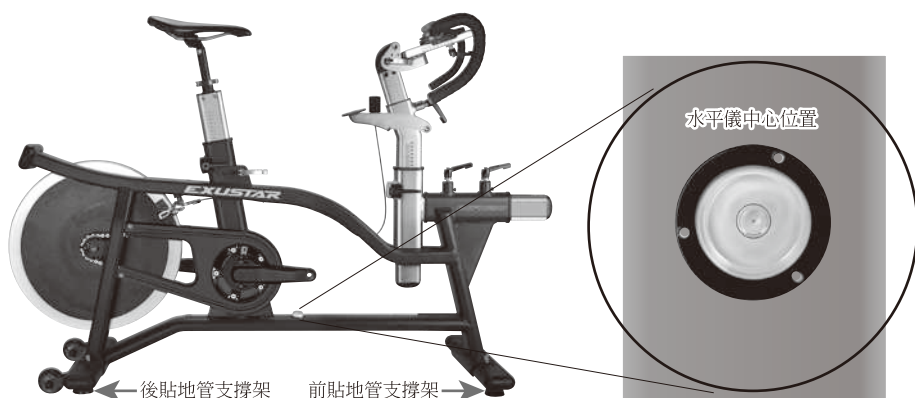

1. 頭管長度調整 (Stack)：測量範圍 500-650mm

在頭管固定快拆鬆開的狀況下，如圖將頭管快拆鬆開，拉起頭管至目標長度（參考量尺），再將快拆鎖緊固定（圖A）。

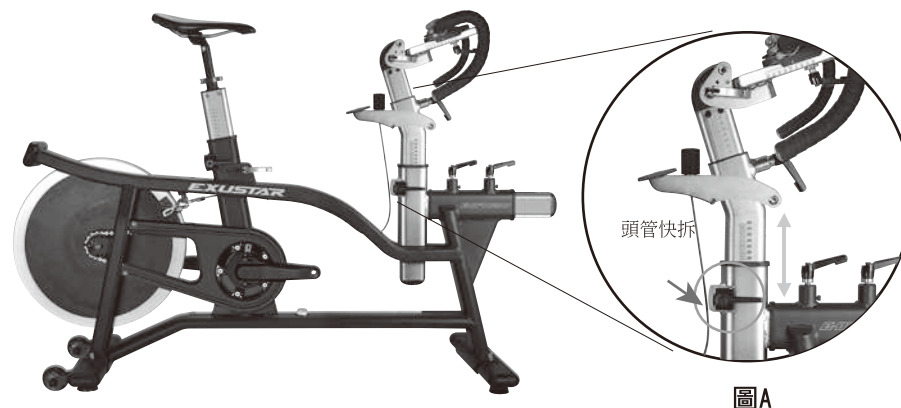

2. 上管水平距離調整 (Reach)：測量範圍 350-420mm

在上管固定快拆鬆開的狀況下，往左或往右調整至目標之長度（參考量尺），再將上管快拆固定（圖B）。

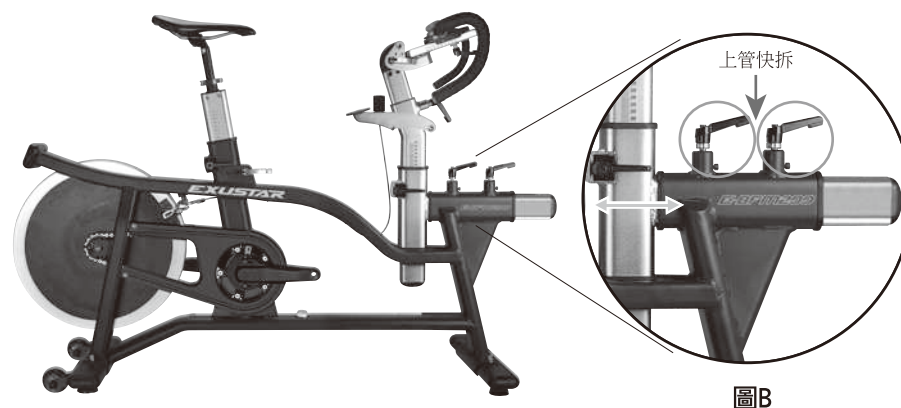

3. 座管角度調整：

步驟1：將水平角度規放置於貼地管，將刻度盤之0° 轉至指標。

步驟2：旋鬆座管角度快拆，將水平角度規放置於座管，調整座管角度改變至目標角度（圖C），再鎖緊座管角度快拆，指標所指的角度即為座管角度。

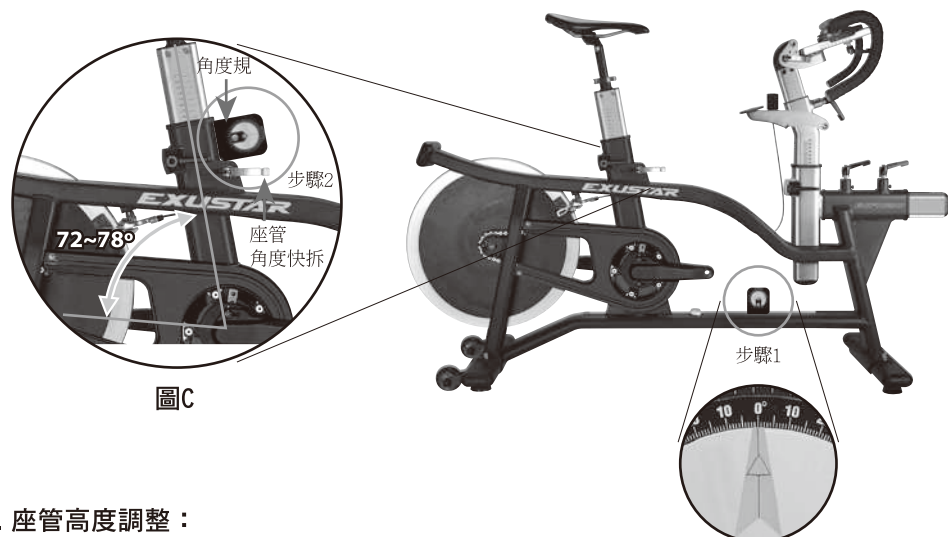

4. 座管高度調整：

旋鬆座管高度快拆，向上或向下調整座管高度至目標高度，再固定座管高度快拆（圖D）。



5. 立管高度調整（Stem）：

放鬆立管高度固定快拆，拉動立管至欲設定之高度，再行鎖緊立管高度固定快拆（圖E）。

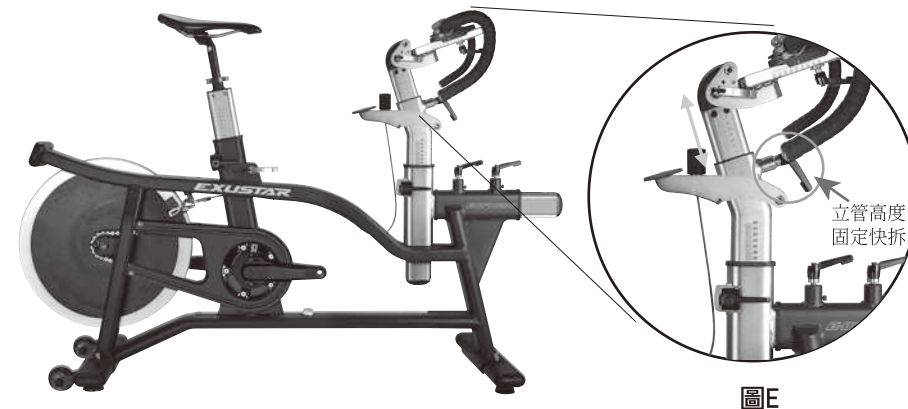

6. 立管角度調整（Stem）：調整範圍 ±12度

步驟1：將水平角度規放置於立管，將刻度盤之90° 轉至指標。

步驟2：放鬆立管角度固定快拆，轉動立管至目標角度，並確實鎖緊固定快拆（圖F），將水平角度規放置於立管，指標所指之角度即為立管角度，0° 左邊為負，0° 右邊為正。

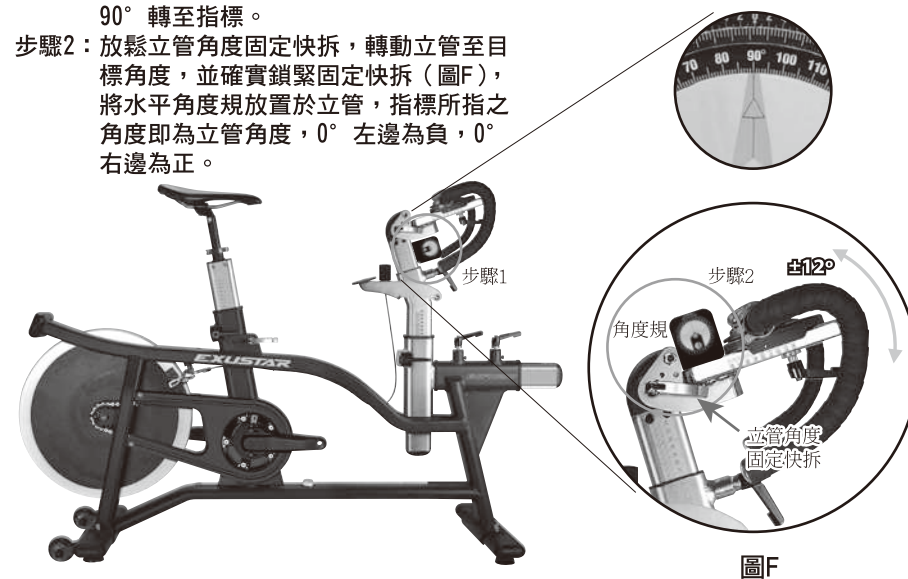

7. 立管長度調整 (Stem) :

旋鬆立管長度固定快拆，將車手把移至欲設定之長度，旋緊立管長度固定快拆 (圖G)。

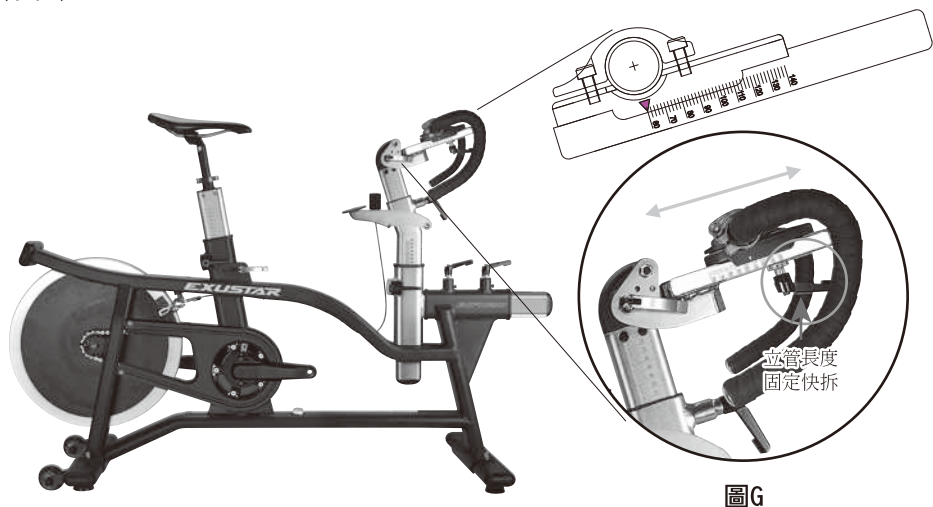

圖G

8. 飛輪摩擦力調整器 :

順時針旋轉減低阻力，逆時針旋轉增加阻力 (圖H)。

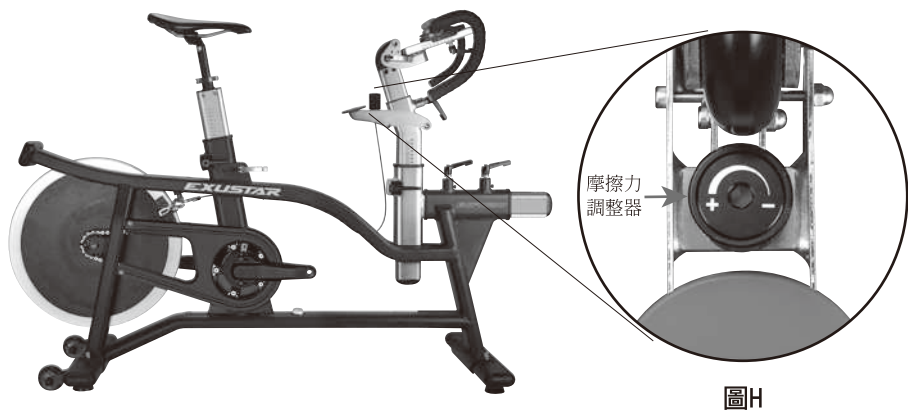

圖H

9. 飛輪煞車 :

測量時，欲停止飛輪，壓下煞車壓板，以讓飛輪煞停 (圖I)。

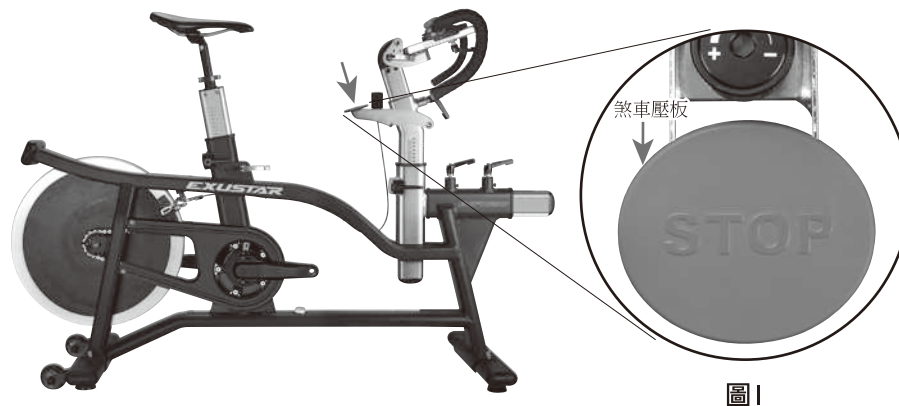

圖I

10. 車手把寬度調整 :

鬆開車手把寬度調整快拆，將車手把往外拉出至理想距離 (參考刻度)，再將快拆鎖緊固定。

11. 曲柄長度調整 :

將曲柄上固定螺絲鬆開後，滑動曲柄至理想長度 (參考刻度量尺)，再將固定螺絲鎖緊 (圖H)。

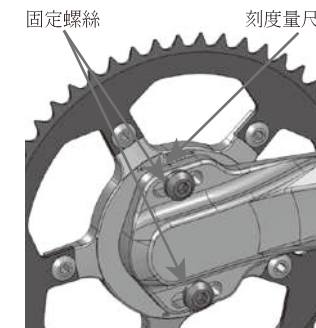

圖H

12. 車手把之更換 :

首先鬆開車手把寬度調整快拆，將車手把往外拉出。再將欲裝之車手把依左右手插入把手孔，再將快拆鎖緊固定。

註：平把車手把所標示之尺寸是指車手把未裝握把時寬度尺寸。
彎把車手把所標示之尺寸是指車手把中心至中心之寬度尺寸。